



SAFETY ISSUES

IMPORTANT – USER SAFETY AND PROTECTION: In setting up systems to fit your operations, care must be taken to select the proper components and design to insure that all safety measures have been taken to avoid the risk of personal injury and property damage from your application or system.

GARDNER BENDER is not RESPONSIBLE FOR DAMAGE OR INJURY CAUSED BY UNSAFE USE, MAINTENANCE OR THE APPLICATION OF ITS PRODUCTS. Please contact Gardner Bender for guidance when you are in doubt as to the proper safety precautions to be taken in designing and setting up your particular application. Technical Support # 1-800-624-4320.

1.0	Safety Symbol Definitions.....	2	9.2	Pulling Downward.....	6-7
2.0	Warning Labels on Product.....	2	9.3	Pulling Sideways.....	7
3.0	Key Safety Information.....	2	10.0	Rope Path General Guidelines.....	7
4.0	Electrical Safety Information.....	2	11.0	Operating Instructions.....	7-8
5.0	Safe Pulling Guidelines.....	2-3	12.0	Transporting the Machine.....	8
6.0	Puller Specifications.....	3	13.0	Maintenance.....	8
7.0	Parts Identification.....	4	14.0	Additional Cable Pulling Accessories.....	8
8.0	Pulling Preparation.....	5			
9.0	Setting Up the Machine.....	5			
	9.1 Pulling Upward.....	5-6			



1.0 SAFETY SYMBOL DEFINITIONS

The instruction manual and labels applied to the product provide information for avoiding injury or death from unsafe practices related to setting up and operating this machine. It is critical that all personnel involved with the use of this machine understand these hazards and unsafe practices. The three levels (Danger, Warning, and Caution) define the severity of the hazard.

⚠ DANGER: Immediate hazards that if not avoided WILL result in severe injury or death.

⚠ WARNING: Serious injury or death COULD occur if proper attention is not observed.

⚠ CAUTION: Injury or property damage MAY occur if proper attention is not observed.





2.0 WARNING LABELS ON PRODUCT

The product has safety related labels securely adhered to it in several locations. They serve to highlight the areas of this machine that have the potential to cause injury if the operator does not use caution. The labels include internationally recognized symbols that are described below.

 Read and understand the instruction sheet before setting up or operating this machine.

 Body parts are in danger of being crushed by moving or moveable parts.

 Body parts are in danger of being entangled in rope.

 Read instruction sheet before operation.



3.0 KEY SAFETY INFORMATION

1. Do not use the cable puller for any other purpose or application beyond its intended use. It is intended for pulling wire or cable through fixed conduit, with the conduit adaptor engaged in the conduit and fastened to the cable puller.
2. Do not operate the cable puller in poorly lit areas.
3. Do not exceed the maximum rated 10,000 lbs. pulling force.
4. Inspect all cable puller components prior to operation.
5. Keep the pull rope away from the operator's feet. Gather the tailing rope in an area where the operator or crew cannot become entangled.
6. Never stand directly under a vertical pull or directly in line with pull rope under tension.
7. Never use general purpose rope; always use double braided polyester rope and inspect the rope for damage after each pull. Do not use damaged rope for pulling cable.
8. Do not allow the rope coils to overlap on the Capstan.
9. Keep bystanders away from operations. Distractions increase chances of injury.
10. Do not use the cable puller while under the influence of drugs, alcohol or medication.
11. Do not operate near water or other liquids.

12. Do not wear jewelry or loose-fitting clothes. Long hair, clothing, body parts and gloves should be clear of moving parts.
13. Always use all personal safety equipment, including eye protection and a hard hat.
14. Do not wrap rope around legs, arms or torso of body.
15. Do not plug Power Cord directly into power source. Power Cord must be plugged into the Footswitch.



4.0 ELECTRICAL SAFETY INFORMATION

Grounding

A three pronged grounded plug is included in the Footswitch and must be plugged into a three hole, properly wired grounded socket. Do not use a three prong to two prong adaptor. Never connect the ground wire to a live terminal.

Extension Cords

1. Using an extension cord reduces the voltage supply to the Motor. Select the appropriate wire size for extension cord length from Table 1.
2. Only extension cords with the suffix W-A following the cord type designation are allowed for outdoor use.
3. Extension cords must have a three prong plug and three prong receptacles.
4. Do not use machine if extension cord has been damaged or abused.

Table 1. Extension Cord Minimum Wire Gauge Guide

Total Amps:	0-5.0	5.1-7.0	7.1-12.0	12.1-16.0	16.1-20.0
Length (ft.)	Wire Gauge	Wire Gauge	Wire Gauge	Wire Gauge	Wire Gauge
25	18	18	16	14	12
50	18	16	14	12	10
75	18	14	12	10	8
100	18	12	10	8	8
150	16	12	8	8	6
200	16	10	8	6	4



5.0 SAFE PULLING GUIDELINES

⚠ DANGER

1. Never expose machine to wet conditions due to electric shock.
2. Do not use or store this machine near exposed live circuits or overhead wires.
3. Do not use a damaged or worn extension or Footswitch cord.

FAILURE TO OBSERVE THESE DANGERS WILL RESULT IN SEVERE INJURY OR DEATH

⚠ WARNING

1. The maximum pulling capacity must not be exceeded.
2. Use the recommended size rope for pulling load. See 6.0 Puller Specifications.
3. Rope may beak or pulling grip may come loose under tension. Stand in the safe zone which is at least 30 degrees to either side of rope. (See Figure 1)
4. Rope must be replaced if the strands are worn or cut.
5. Use the correct size Conduit Adaptor.

FAILURE TO OBSERVE THESE WARNINGS COULD RESULT IN SEVERE INJURY OR DEATH

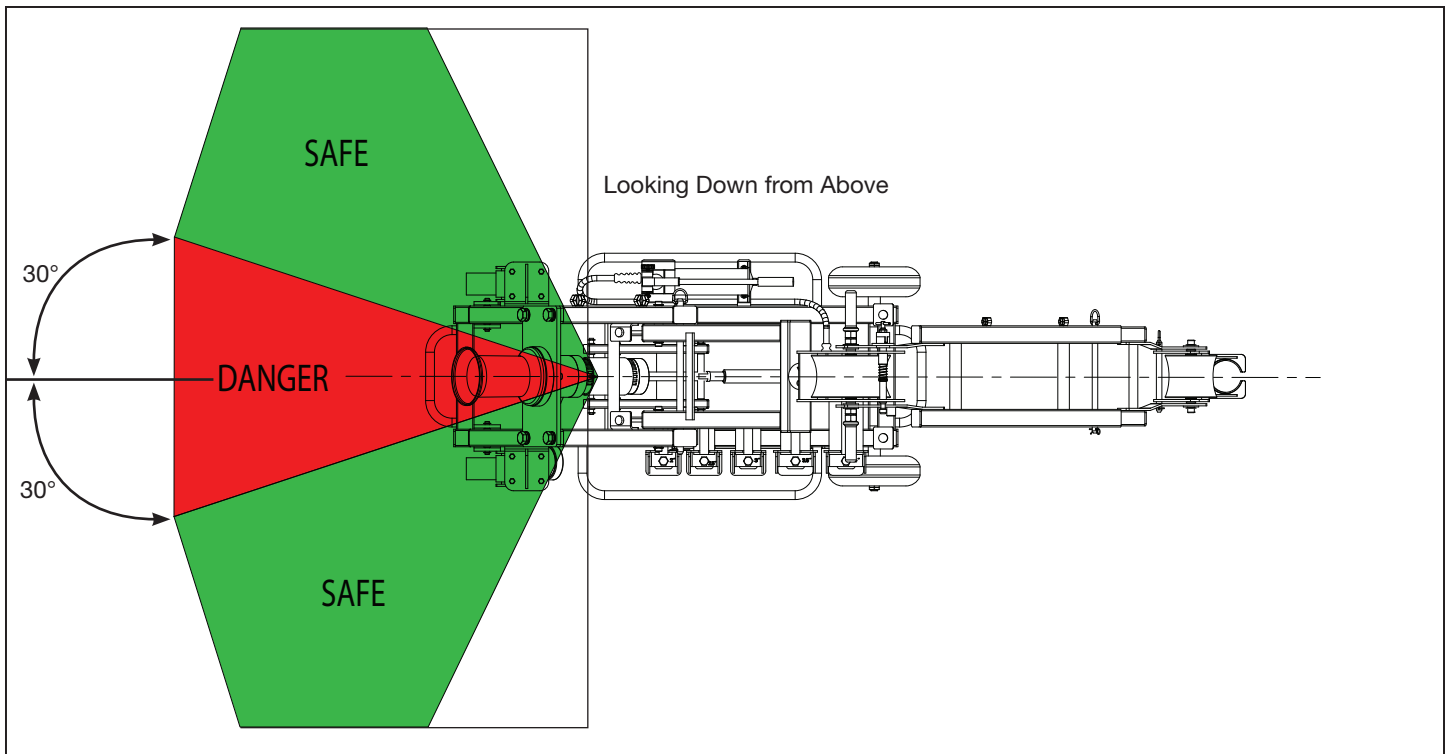

Figure 1. Stand in Safe Zone

⚠ CAUTION

1. Inspect machine to be free of all rust, dirt and grit.
2. Eye protection, hard hats and all personal safety equipment needs to be worn.
3. Power Cord must be plugged into Footswitch.
4. Do not allow rope to rub anywhere other than pulley rollers and Capstan.
5. Do not wear loose fitting clothes.

FAILURE TO OBSERVE THESE CAUTIONS MAY RESULT IN SEVERE INJURY OR DEATH



6.0 PULLER SPECIFICATIONS

Table 2. Puller Specifications

Weight	Shipping Weight	455 lbs.
	Product Weight	385 lbs.
Shipping Dimensions	Pallet	66" wide x 36" deep
	Overall Height (includes pallet):	44"
Product Dimensions	Wheel Span	28"
	Length	61"
	Height	39"
Motor	Volts	115 VDC
	Current	14 amps
	Type	1-phase
Pulling Force	Max Capacity (Intermittent Duty)	10,000 lbs.
	Continuous	8,000 lbs.
Rope	Green & Yellow Zone on Pull Meter	3/4" double braided polyester rope
	Red Zone on Pull Meter	7/8" double braided polyester rope

⚠ CAUTION

1. Inspect pulling rope. Do not use if damaged.
2. Do not allow rope to rub anywhere other than pulley rollers and Capstan.
3. Do not exceed capacity of Motor force. Observe Pull Meter for reference.

FAILURE TO OBSERVE THESE CAUTIONS MAY RESULT IN DAMAGING MACHINE MOTOR OR SEVERE INJURY

- | | |
|-------------------------------|-------------------------------|
| 1. Steering Handles | 12. Pulley-B Housing |
| 2. Caster Wheels & Brakes | 13. Pulley-B Housing Lock Pin |
| 3. Hydraulic Pump | 14. Pull Orientation Pivot |
| 4. Main Boom | 15. Pull Orientation Pin |
| 5. Boom-A | 16. Conduit Adaptors |
| 6. Boom-B | 17. Power Cord |
| 7. Boom-A Lock Pin | 18. Footswitch |
| 8. Pulley-A Housing | 19. Pull Meter & Switch Box |
| 9. Boom-B Lock Pin | 20. Capstan |
| 10. Boom-B Extension | 21. Motor |
| 11. Boom-B Extension Lock Pin | 22. Pin Clips |

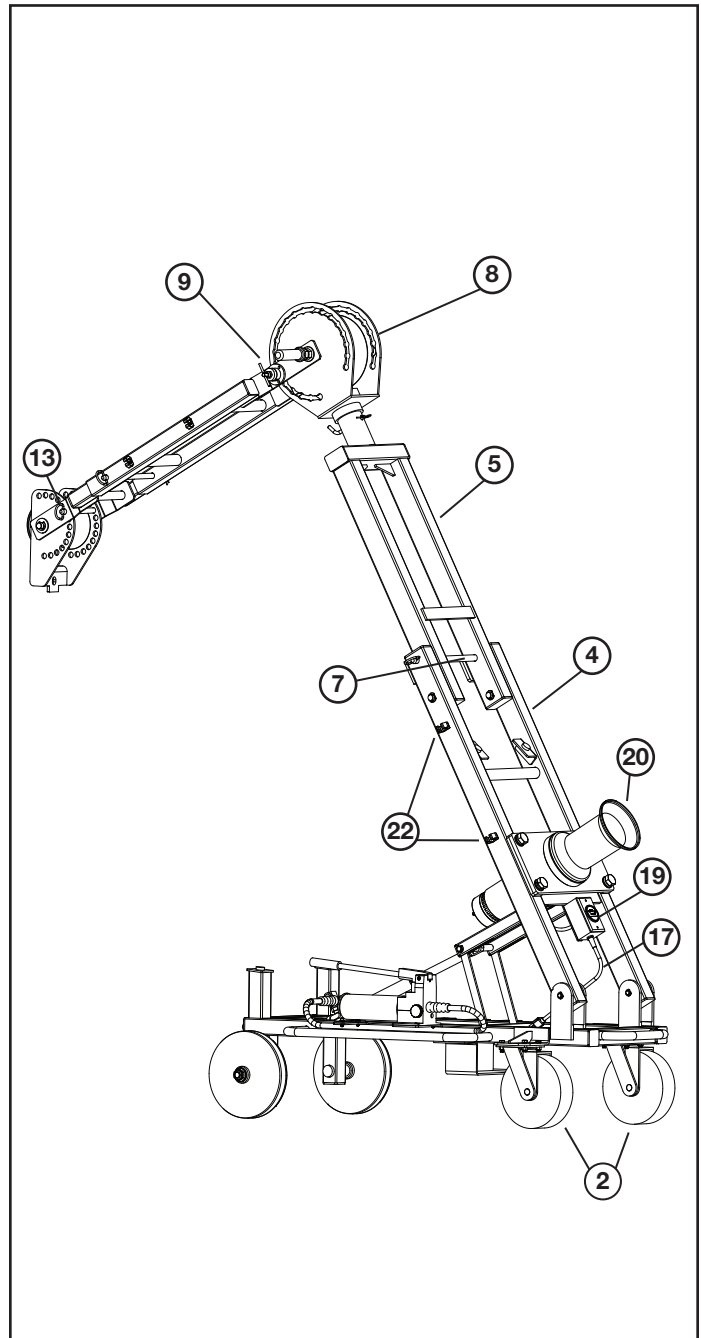
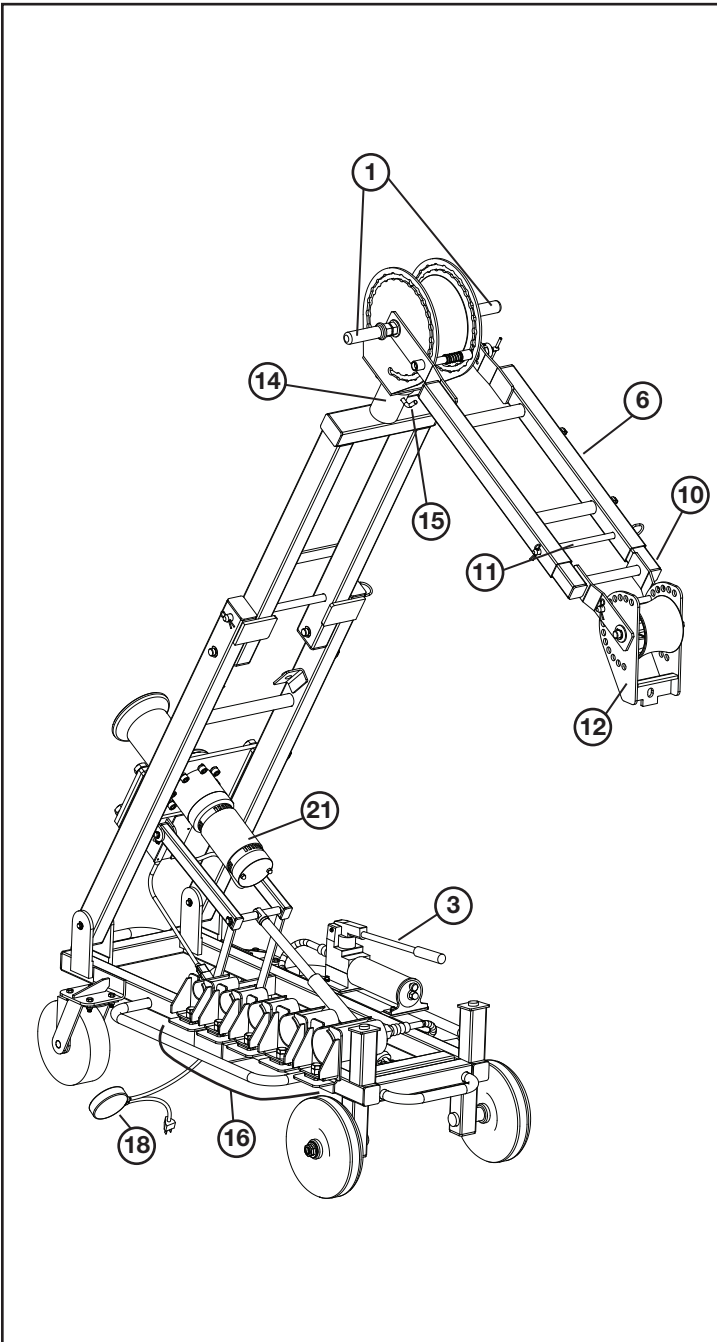

If all cable diameters within the bundle are the same, select your grip from Table 3.

Table 3. Pulling Grip Guide With Known Cable Diameter

Number of Cables in Each Grip and Diameter Range INDIVIDUAL CABLE DIAMETERS				GRIP DIAMETER
2	3	4	5	Range
.30 – .38	.25 – .31	.22 – .27	.19 – .24	.50 – .61
.38 – .44	.31 – .36	.27 – .31	.24 – .29	.62 – .74
.44 – .59	.36 – .49	.31 – .42	.29 – .38	.75 – .99
.59 – .75	.49 – .63	.42 – .54	.38 – .48	1.00 – 1.24
.75 – .90	.63 – .76	.54 – .65	.48 – .58	1.25 – 1.49
.90 – 1.07	.76 – .89	.65 – .77	.58 – .67	1.50 – 1.74
1.07 – 1.22	.89 – 1.02	.77 – .88	.67 – .77	1.75 – 1.99
1.22 – 1.53	1.02 – 1.28	.88 – 1.10	.77 – .96	2.00 – 2.49
1.53 – 1.83	1.28 – 1.53	1.10 – 1.32	.96 – 1.16	2.50 – 2.99
1.83 – 2.14	1.53 – 1.79	1.32 – 1.54	1.16 – 1.35	3.00 – 3.49
2.14 – 2.44	1.79 – 2.05	1.54 – 1.76	1.35 – 1.54	3.50 – 3.99
2.44 – 2.75	2.05 – 2.30	1.76 – 1.98	1.54 – 1.74	4.00 – 4.49
2.75 – 3.06	2.30 – 2.56	1.98 – 2.20	1.74 – 1.93	4.50 – 4.99



If individual cable diameter is not known, or the cables within the bundle are of different diameter, use Table 4.

Table 4. Pulling Grip Guide With Unknown Cable Diameter

CIRCUMFERENCE RANGE (inches)	GRIP DIAMETER RANGE (inches)
1.57 – 1.95	.50 – .61
1.95 – 2.36	.62 – .74
2.36 – 3.14	.75 – .99
3.14 – 3.93	1.00 – 1.24
3.93 – 4.71	1.25 – 1.49
4.71 – 5.50	1.50 – 1.74
5.50 – 6.28	1.75 – 1.99
6.28 – 7.85	2.00 – 2.49
7.85 – 9.42	2.50 – 2.99
9.42 – 11.00	3.00 – 3.49
11.00 – 12.57	3.50 – 3.99
12.57 – 14.14	4.00 – 4.49
14.14 – 15.71	4.50 – 4.99

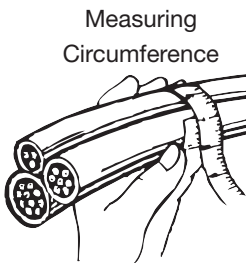

WARNING

1. Inspect rope for damage prior to use. Do not use a damaged rope. Using a damaged rope can result in a pull failure and damage to the cables.
2. Inspect the pulling grip for damage prior to use. Do not use a damaged pulling grip. Using a damaged pulling grip can result in a pull failure and damage to the cables.

FAILURE TO OBSERVE THESE WARNINGS COULD RESULT IN SEVERE INJURY OR DEATH

9.1 PULLING UPWARD

1. Position the machine near the conduit box, leaving enough room to unfold and properly adjust the boom structure.
2. Lock the brakes on the casters.
3. Close the Hydraulic Pump valve by turning clockwise. **Do not over-torque.**
4. Release the pump handle lock and pump the Main Boom up to a 30 degree angle. The Main Boom pivot bracket is marked for 30 degrees. (See Picture 1)

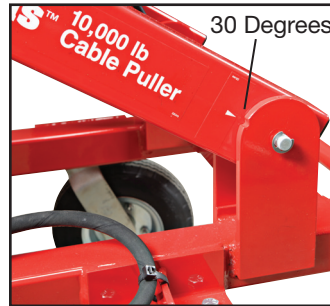

Picture 1



Picture 2

5. Remove Boom-A Lock Pin and temporarily store in Pin Clips.

⚠ DANGER: Check for overhead wires prior to unfolding the boom structure.

FAILURE TO OBSERVE THESE DANGERS WILL RESULT IN SEVERE INJURY OR DEATH

6. With one hand on the Steering Handle and one hand on Boom-B, lift and rotate Boom-A and Boom-B together until it stops inline with the Main Boom. (See Picture 2)

⚠ WARNING: If you do not place your hands as instructed, then you may crush your hand or fingers. If you do not observe the machine warning labels, you may crush your hand or fingers.

FAILURE TO OBSERVE THESE WARNINGS COULD RESULT IN SEVERE INJURY OR DEATH

7. Re-insert Boom-A Lock Pin and retaining clip. **!! This is extremely important !!**
8. While holding on to Boom-B securely, release the Boom-B Lock Pin. Adjust angle of Boom-B and re-engage the Boom-B Lock Pin to secure it. **Confirm the pin is fully engaged.** (See Picture 3)



Picture 3



Picture 4

9. If necessary, adjust the length of Boom-B with the Boom-B Extension. Remove Boom-B Extension Lock Pin and slide out the extension to one of 5 lock holes. (See Picture 4)
10. Select the correct size Conduit Adaptor, which is stored on the machine cart frame.

- Align the Conduit Adaptor hole with the Pulley-B Housing bracket hole and tighten securely with the provided Conduit Adaptor hex-head bolt. (See Picture 5)

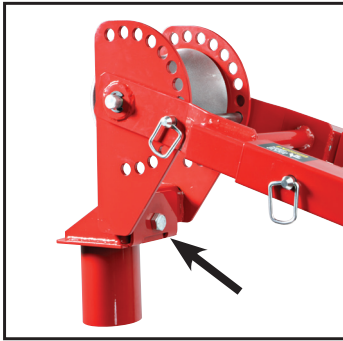

Picture 5

- Remove Pulley-B Housing Lock Pin.
- Release the brakes on casters and re-position machine reasonably perpendicular to conduit wall.
- Make final adjustments until the Conduit Adapter is properly inserted inside of the conduit.
 - The Main Boom angle can be increased by pumping the Hydraulic Pump. The angle can be reduced by slowly opening the pump valve. **!! Use Caution !!**
 - The angle of Boom-B, the length of Boom-B, and the Pulley-B Housing angle can be adjusted as needed.
- Install the Pulley-B Housing Lock Pin to secure the pulley housing.

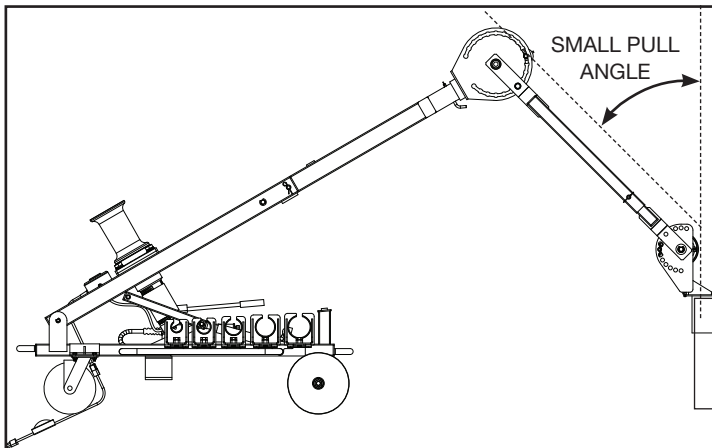

- In general, the pull angle should be kept small as shown above. Try to set up the machine so that Boom-B is not at a large angle relative to the conduit. For conduit boxes further from the ground, this is not always possible.

⚠ WARNING: For all set-up conditions, the rope must be in contact with both pulleys. If the rope is not in contact with both pulleys, then the Boom structure WILL fail under load.

FAILURE TO OBSERVE THESE WARNINGS COULD RESULT IN SEVERE INJURY OR DEATH

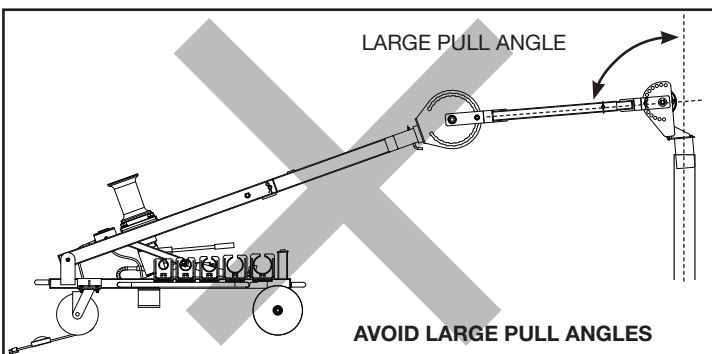

9.2 PULLING DOWNWARD

- Start by following steps 1 through 8 as described in PULLING UPWARD.
- To set-up the machine for downward pulling, Boom-B has to be rotated 180 degrees at the Pull Orientation Pivot (Part 14). **Do not do this by removing Boom-B extension and re-installing it upside down.**
- Remove the Pull Orientation Pin. (See Picture 6)



Picture 6

- Rotate Pulley-A Housing and Boom-B together 180 degrees. You will see a label at the pivot joint that reads "Downward Pulling". This label should be on top. (See Picture 7)

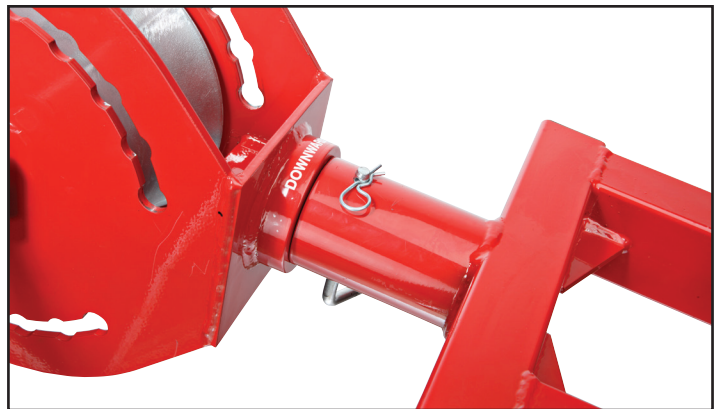

Picture 7

- Replace and secure the Pull Orientation Pin.
- Remove Pulley-B Housing Lock Pin and temporarily store it in the side clips of Boom-B. You will re-install it after engaging the Conduit Adaptor with the conduit opening.
- Make preliminary adjustments to position the Main Boom, Boom-A and Boom-B for a downward pull to assure that rope will contact both pulleys.
- Release the brakes on the casters and re-position the machine perpendicular to the conduit wall.
- Make final adjustments until the Conduit Adapter is properly inserted inside of the conduit.
 - The Main Boom angle can be increased by pumping the Hydraulic Pump. The angle can be reduced by slowly opening the pump valve. **!! Use Caution !!**
 - The angle of Boom-B, the length of Boom-B, and the Pulley-B Housing angle can be adjusted as needed.
- Install the Pulley-B Housing Lock Pin to secure the pulley housing.

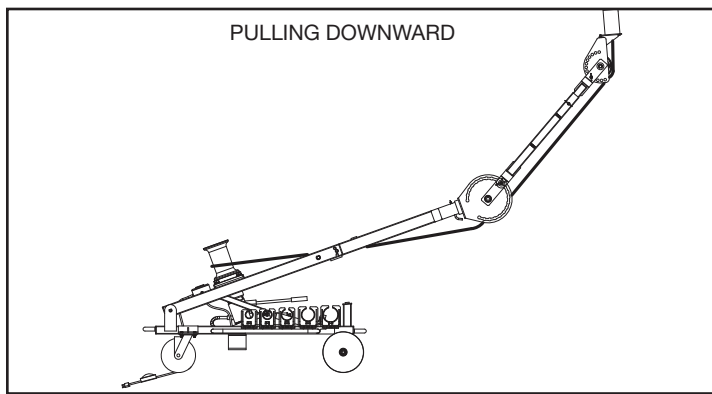

⚠ CAUTION: There are no set-up conditions that the rope should pass through Boom-B.

FAILURE TO OBSERVE THESE CAUTIONS MAY RESULT IN SEVERE INJURY OR DEATH

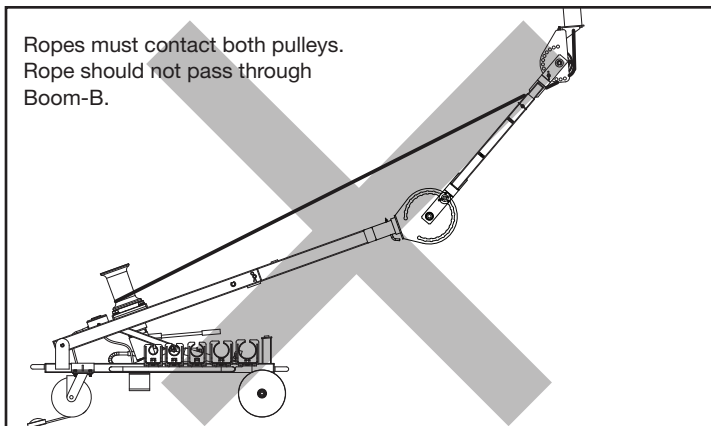

9.3 PULLING SIDWAYS

1. Start by following steps 1 through 8 as described in PULLING UPWARD.
2. To set up the machine for sideways pulling, Boom-B has to be rotated 90 degrees at the Pull Orientation Pivot (Part 14).
3. Remove the Pull Orientation Pin. (See Picture 6)
4. Rotate Pulley-A Housing and Boom-B together 90 degrees. (See Picture 8)



Picture 8

5. Replace and secure the Pull Orientation Pin.
6. Remove Pulley-B Housing Lock Pin and temporarily store it in the side clips of Boom-B. You will re-install it after engaging the Conduit Adaptor with the conduit opening.
7. Make preliminary adjustments to position the Main Boom, Boom-A and Boom-B for a sideways pull to assure that rope will contact both pulleys.
8. Release the brakes on the casters and re-position the machine perpendicular to the conduit wall.

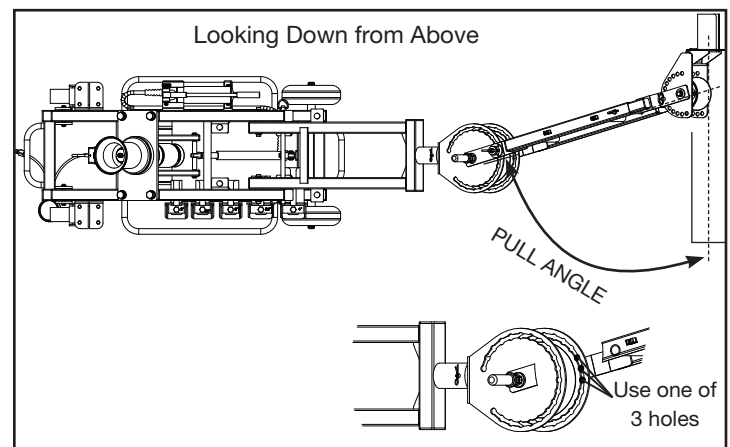

9. Adjust Boom-B angle for sideways pulling. Use one of the 3 holes on Pulley-A Housing shown above to minimize the load on the boom structure.

10. Make final adjustments until the Conduit Adapter is properly inserted inside of the conduit.
 - The Main Boom angle can be increased by pumping the Hydraulic Pump. The angle can be reduced by slowly opening the pump valve. **!! Use Caution !!**
 - The angle of Boom-B, the length of Boom-B, and the Pulley-B Housing angle can be adjusted as needed.

11. Install the Pulley-B Housing Lock Pin to secure the pulley housing.



10.0 ROPE PATH GENERAL GUIDELINES (All Set-ups)

1. A small pull angle is better than a large pull angle as it places less stress on the cable being pulled.
2. If the rope is not contacting both rollers, then the set-up is wrong.
3. If the rope passes through Boom-B or Boom-B Extensions, then the set-up is wrong.
4. If the rope is rubbing on the Boom-Structure or the Conduit Adaptor, then the set-up is wrong.
5. The only time that the rope should rub a non-pulley surface is in the set-up for a downward pull. In this case, the rope might contact the Boom-A Lock Pin. This is okay as the lock pin has a smooth, round outer surface.



11.0 OPERATING INSTRUCTIONS

1. Set-up the machine. **READ 9.0 SETTING UP THE MACHINE.**
2. Route the rope from the conduit opening, across both pulleys, to the Capstan. **READ 10.0 ROPE PATH GUIDELINES.**
3. Wrap the rope around the Capstan counter-clockwise from the top. Use 3 to 4 wraps minimum and additional wraps for heavy pulls. Six to eight feet of rope should be free for the start of a pull.
4. Set-up the Footswitch. Plug the cord from the machine's pull Meter Box into the Footswitch cord receptacle. Make certain that the switch on the meter box is set to OFF. Plug the Footswitch plug into a 115V 3-prong grounded socket or extension cord receptacle. **READ EXTENSION CORD WIRE GAUGE GUIDE.**

⚠ WARNING: DO NOT CONNECT THE MACHINE'S CORD DIRECTLY TO A POWER SOURCE. The machine must be activated only with the Footswitch.

FAILURE TO OBSERVE THESE WARNINGS COULD RESULT IN SEVERE INJURY OR DEATH

5. Perform a final safety check as follows, prior to initiating the pull.

5 CHECK PINS

- A. Pulley-B Housing Lock Pin is secure
- B. Boom-B Extension Lock Pin is secure
- C. Boom-B Lock Pin is secure and completely engaged
- D. Pull Orientation Pin is secure
- E. Boom-A Lock Pin is secure
- F. Conduit Adaptor Bolt is secure
- G. The Footswitch has been positioned in the safe-pull zone (See Figure 1)
- H. The operator is not wearing any loose clothing
- I. There is no one standing in line with the rope

6. Turn on the switch at the Meter & Switch Box.

7. Activate the Capstan rotation by stepping on the Footswitch.

8. Gradually apply tension to the rope to begin the pull.

⚠ WARNING: Immediately remove foot from Footswitch if Boom Structure becomes unsteady or if pulling rope becomes entangled.

FAILURE TO OBSERVE THIS WARNING COULD RESULT IN SEVERE INJURY OR DEATH

- Occasionally lubricate caster axles (zinc fitting).
- Occasionally lubricate 10" Wheel axles (zinc fitting).
- Check and refill the Hydraulic Pump oil with Enerpac PN LX101 if needed.
- Check for hydraulic fluid leaks.
- Touch up any paint scratches to prevent oxidation of metal structure. Oxidation can weaken the steel structure and result in failure under load.
- Check and adjust tire pressure (4 places).
- Occasionally lubricate Boom-B Extension.
- Replace pins & retention clips if missing. (**!! CRITICAL !!**)



14.0 ADDITIONAL CABLE PULLING ACCESSORIES



12.0 TRANSPORTING THE MACHINE

1. Remove the Conduit Adaptor prior to collapsing.

2. Restore the machine to its folded, collapsed position.

3. Unlock the brakes on the casters prior to moving the machine.

⚠ WARNING: Collapsing the machine improperly can be extremely unsafe if not done properly. There are numerous opportunities to severely injure your fingers and hands. The machine is equipped with numerous warning labels to help highlight the potential pinch points. However, not all pinch points are labeled. Never use gripping locations near a potential pinch point.

FAILURE TO OBSERVE THESE WARNINGS COULD RESULT IN SEVERE INJURY OR DEATH



13.0 MAINTENANCE

- Inspect and clean all surfaces before each operation.
- Check for Power Cord and Footswitch Cord damage. Replace if damaged.
- Replace any components that are not functioning properly.
- Occasionally lubricate caster pivots (zinc fitting).

REPAIR AND SERVICE INSTRUCTIONS: For repair service and parts contact your nearest Gardner Bender Service Center or refer to enclosed service manuals. The Gardner Bender Service Center will provide complete and prompt service on all Gardner Bender products.

PARTS AND SERVICE: For quality workmanship and genuine Gardner Bender parts, select an Authorized GB Service Center for your repair needs. Only repairs performed by an Authorized Service Center displaying the official GB Authorized sign are backed with full factory warranty. Contact Gardner Bender (414)352-4160 for the name of the nearest GB Authorized Service Center.

WARRANTY: Gardner Bender warrants its product against defects in workmanship and materials for 1 year from date of delivery to user. Warranty does not cover ordinary wear and tear, abuse, misuse, overloading, altered products or use of improper fluid.

WARRANTY RETURN PROCEDURE: When question of warranty claim arises, send the unit to the nearest GB Authorized Service Center for inspection, transportation prepaid. Furnish evidence of purchase date. If the claim comes under the terms of our warranty the Authorized Service Center will REPAIR OR REPLACE PARTS AFFECTED and return the unit prepaid.

IMPORTANT: RECEIVING INSTRUCTIONS

Visually inspect all components for shipping damage. If you find damage, notify the carrier at once. Shipping damage is NOT covered by warranty. The carrier is responsible for all repair or replacement costs resulting from damage in shipment.